

BABY LOCK SEWING ACCESSORIES

Button Sewing Foot

(BLQ2-BS)

Instructions



Attach 2 or 4-hole buttons to garments and other projects with your machine. This convenient foot holds buttons in place, allowing your machine to attach buttons to fabric with a sturdy zigzag stitch. This foot is perfect for buttons that can lay flat without much thread shank.

INSTRUCTIONS:

Removing the presser foot

Raise the presser foot (a).

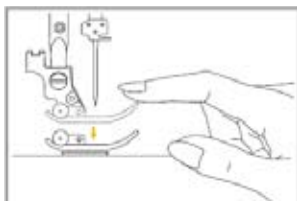

Attaching the presser foot

Lower the presser foot holder (b) until the notch (c) is directly above the pin (d). Lower the presser foot holder (b) and the presser foot (e) will engage automatically.

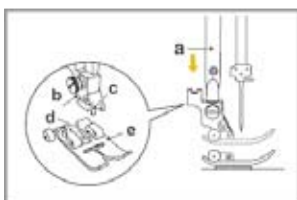

1. Remove the presser foot.
2. Attach the Button Sewing Foot.
3. Select stitch #43 from group 2-B
4. Place the fabric under the foot. Place the button in the desired position, lower the presser foot lever.
5. Adjust the stitch width according to the distance between the two holes of the button.
6. Turn the handwheel counter clockwise to check that the needle goes cleanly into the left and right holes of the button.

NOTE: Sew at a slow speed to avoid hitting the button.

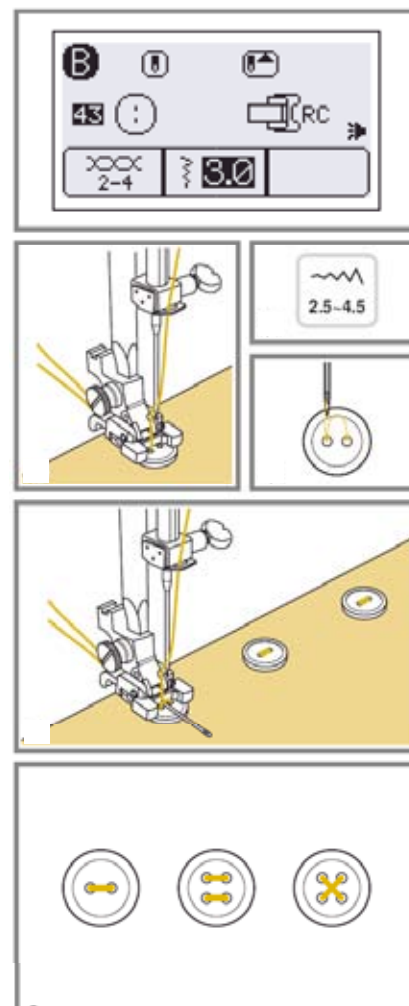

FOR THE LOVE OF SEWING

7. Hold the end of the upper thread gently and begin sewing.
Once sewing is completed, the machine automatically sews reinforcement stitches then stops.

NOTE: Repeat this procedure to attach the button more securely.

8. With scissors, cut the upper and bobbin threads at the beginning of the stitching, pull the upper thread at the end of the stitching to the wrong side of the fabric, and then tie it with the bobbin thread.
9. For a 4-hole button, sew the two holes towards the front.
Then raise the presser foot, move the fabric so that the needle goes into the back two holes, and then sew in the same way.

NOTE: If a shank is required, place a needle or straight pin on top of the button and sew.



FOR THE LOVE OF SEWING

800-422-2952

www.babylock.com