

BABY LOCK SEWING ACCESSORIES

Buttonhole Foot

(BLQ2-BH)

Instructions

When it comes to buttonholes, the perfect fit is key. This snap-on foot actually measures your button for you with a clamp system, so you'll sew even-sized and precise buttonholes every time! The built-in thread guides will even allow you to create corded buttonholes!



INSTRUCTIONS:

Removing the presser foot

Raise the presser foot (a).

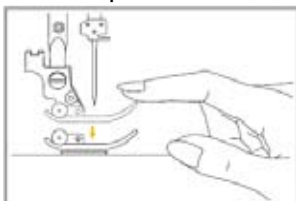

Attaching the presser foot

Lower the presser foot holder (b) until the notch (c) is directly above the pin (d). Lower the presser foot holder (b) and the presser foot (e) will engage automatically.

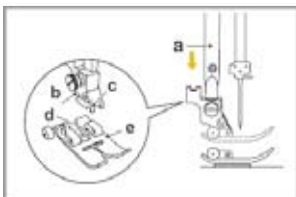

Machine Settings

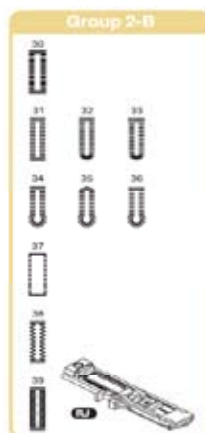

Recommended	Recommended	
0.3-1.0	3.0-7.0	30: For horizontal holes on blouses or shirts made from thin or medium fabric.
0.3-1.0	2.5-7.0	31: For thin or medium fabric.
0.3-1.0	5.5-7.0	32: For thin or medium fabric.
0.3-1.0	2.5-7.0	33: For horizontal buttonholes on thick fabrics.
0.3-3.0	2.5-7.0	34: For suits or overcoats.
1.0-3.0	2.5-7.0	35: For jeans or trousers.
2.0-3.0	3.5-7.0	36: For thick coats.
		37: For bound button holes.
		38: For jeans or stretch fabric with a coarse weave.
		39: For stretch fabric.

Note: Before sewing a buttonhole on your project, practice on a scrap piece of the same type of fabric.

1. Remove the presser foot.
2. Attach the Buttonhole Foot.
3. Mark the position of the buttonholes on the fabric. The maximum buttonhole length is 3cm (1 3/16"). (Total of diameter + thickness of button.)



FOR THE LOVE OF SEWING

4. Attach the buttonhole foot, the buttonhole is determined by the button inserted in the button plate.

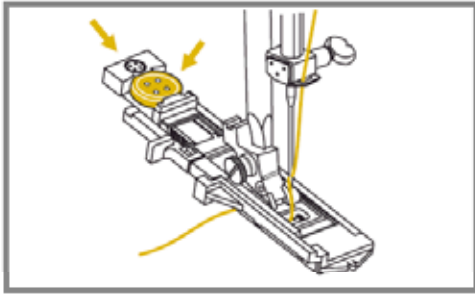

5. The upper thread should be passed through the needle opening in the buttonhole foot, then the thread placed under the foot as illustrated.

6. Select your preferred buttonhole stitch.

7. Adjust the stitch width and the stitch length to the desired width and density.

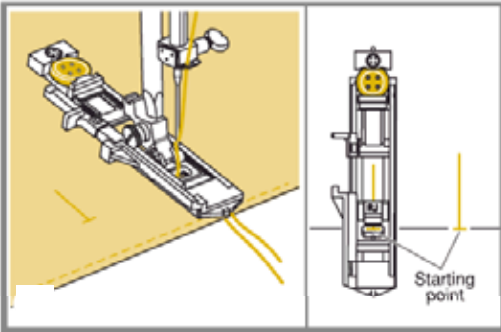

8. Position the fabric under the presser foot with the front end of the buttonhole mark aligned with the center line on the buttonhole foot.

9. Pull the buttonhole lever all the way down and position it behind the bracket on the buttonhole foot.

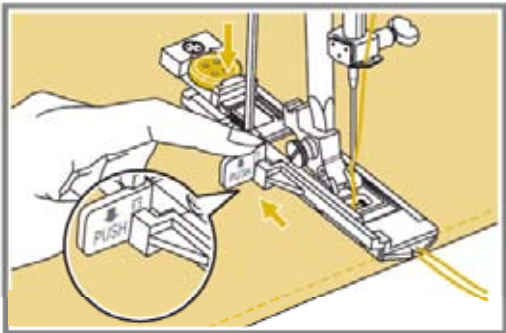

10. While lightly holding the upper thread start sewing.

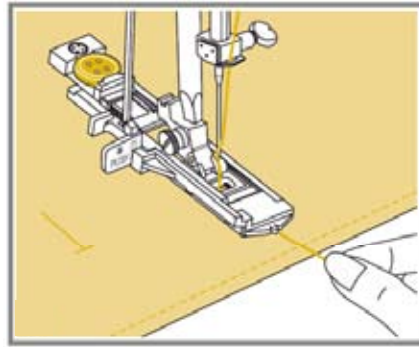

11. Buttonholes are sewn from the front to the back.

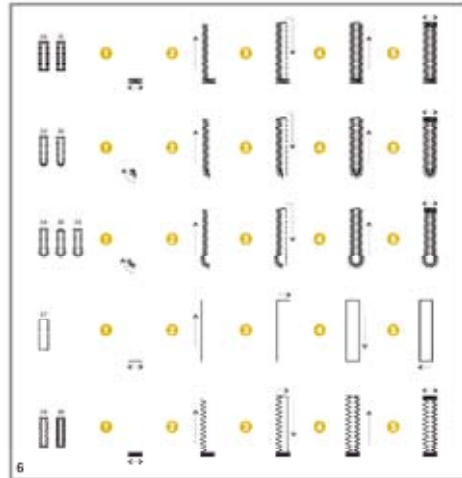

12. Raise the presser foot and cut the thread. To restart the same buttonhole at the beginning, raise the presser foot to return to the starting position. After sewing the buttonholes, raise the buttonhole lever all the way up to its original position for other sewing.

13. Cut the center of the buttonhole being careful not to cut any of the buttonhole stitching. Use a pin as a stopper at the bartack to prevent the stitches on the ends from being cut.

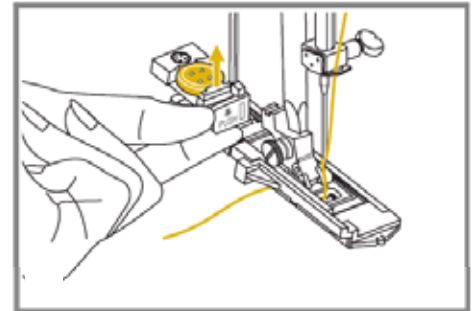

FOR THE LOVE OF SEWING

800-422-2952

www.babylock.com