

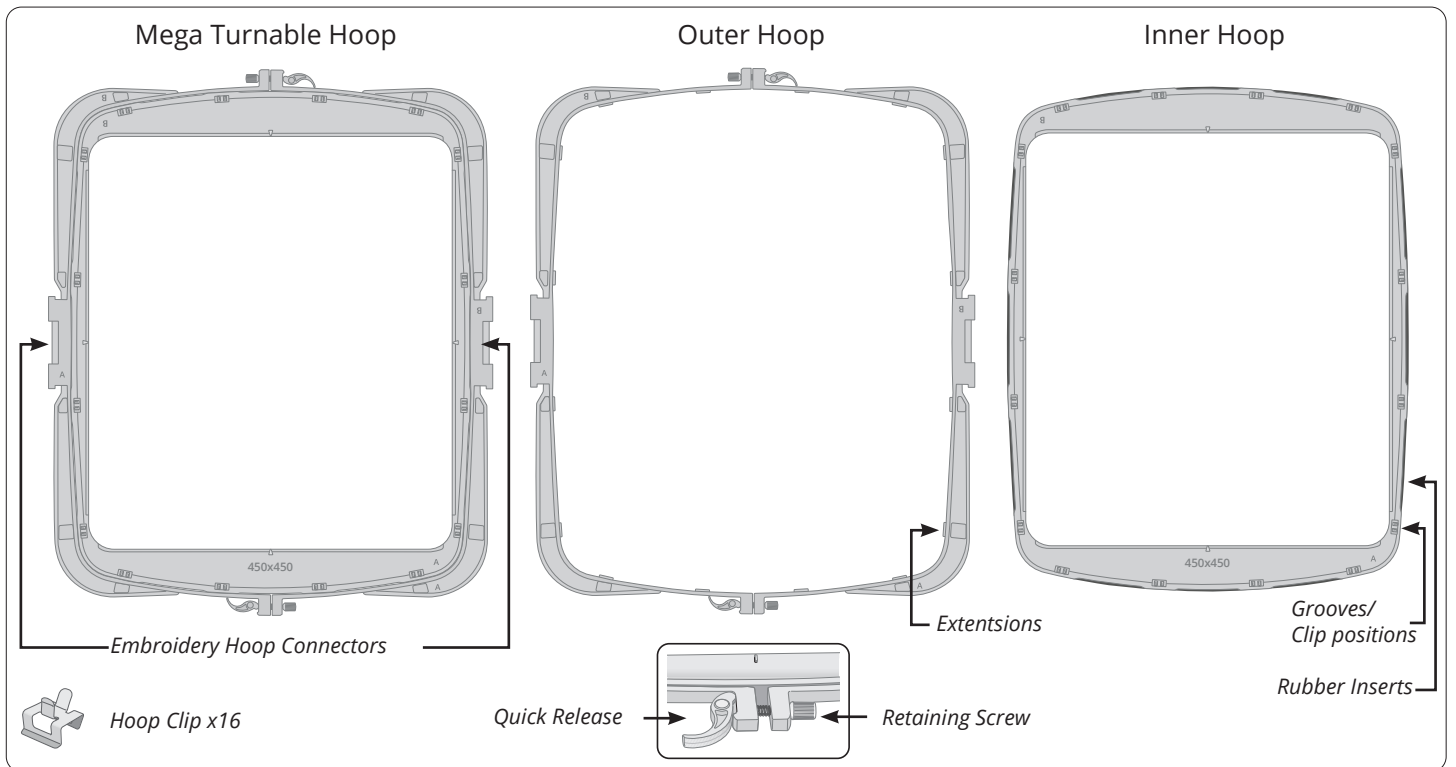

MEGA TURNABLE HOOP
450x450MM

User Instructions

The Mega Turnable Hoop offers an impressive embroidery area of 450x450 mm. You can start to embroider right away using any of the turnable hoop designs included with your machine.



HOW TO HOOP THE MEGA TURNABLE HOOP

The embroidery surface measures 450x450mm. This is a large embroidery area and for the best result, it is important to hoop the fabric properly and taut in the hoop.

- Place the hoop on a flat surface. Release the retaining screws and open both of the quick releases. Remove the inner hoop.
- Place suitable stabilizer and fabric on top of the outer hoop. Place the inner hoop on top of the outer hoop/stabilizer/fabric. Make sure the "A:s" and the "B:s" on the inner and outer hoops match for correct hooping.
- Push the inner hoop firmly into the outer hoop. When pushed properly together, the extensions on the outer hoop should sit into the grooves on the inner hoop. Together with the rubber inserts on the inner hoop, this will create a snug fit. This will prevent you from accidentally pushing the inner hoop too far through the outer hoop.
- Close the quick releases. Carefully pull the fabric outside the hoop towards the center until it is flat and taut in the hoop. Adjust the pressure of the outer hoop by turning the retaining screws evenly on both sides. The fabric should be taut in the hoop for the best results.
- Attach all hoop clips provided on to the hoop.

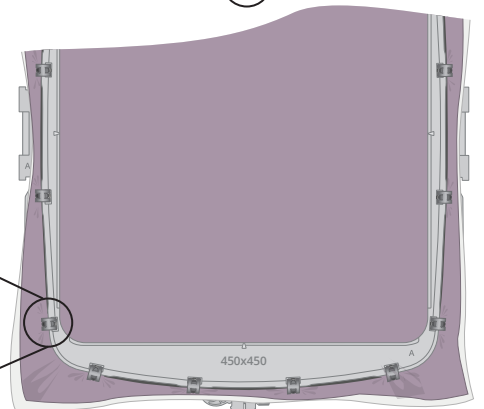
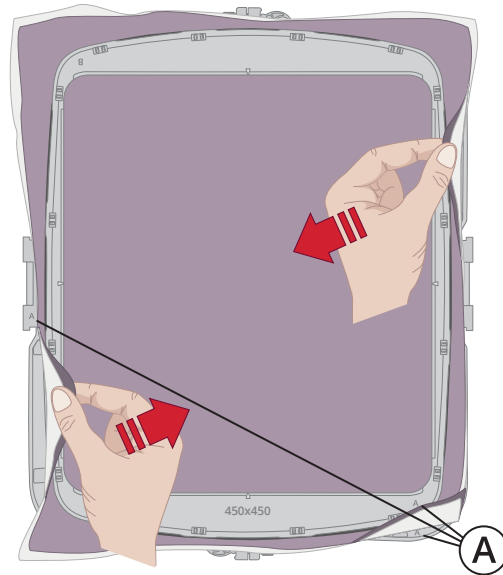
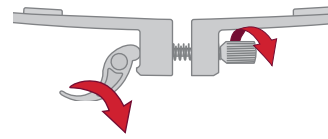
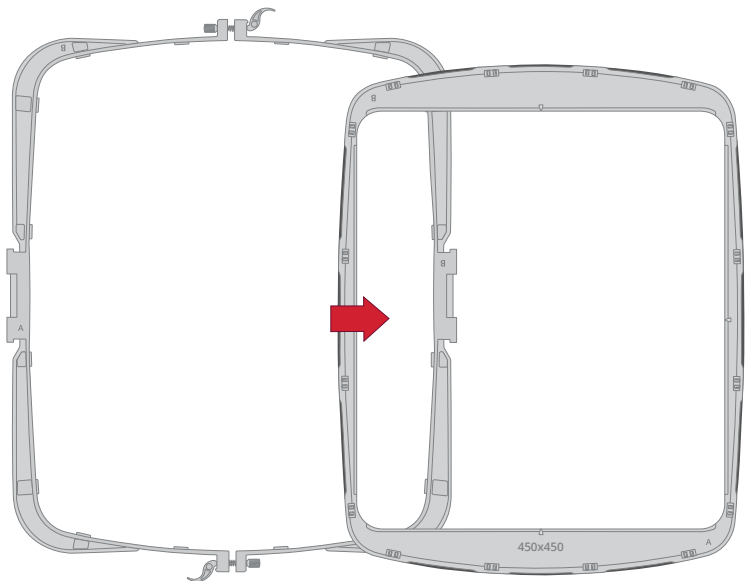

Note: When embroidering with the 450x450 mm hoop, make sure to mount the embroidery extension and the large hoop supports to your embroidery unit/machine.

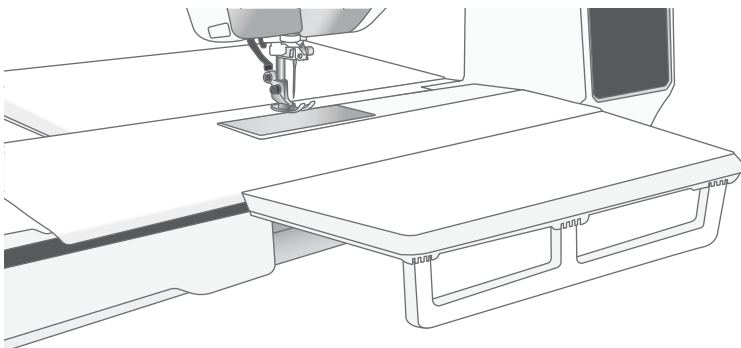

POSITIONING THE DESIGNS ON SCREEN

You can start to embroider right away using any of the turnable hoop designs included with your machine. Those designs are created in two halves, positioned at each side of the hoop. In the design booklet available online (or by following the QR code shown here), the 450x450 hoop is indicated by a turnable hoop icon.

Note: A few of the built-in designs are placed slightly off the center position of the embroidery area. This is to make sure that no part of the design is placed across the overlap area.

You can also create your own design by placing several designs in the hoop area.

When the 450x450mm hoop is selected in the hoop options menu, the A and B sides are highlighted in the embroidery area. In the center of the embroidery area there is a 30mm overlap.

When creating your own embroidery, the respective designs must be placed fully within either side A or B.

If the design is placed over both sides, across the overlap area, it cannot be stitch out, but must be moved to either side before entering Embroidery Stitch-Out.

The designs will be embroidered in the order they are entered into the embroidery area. If you have placed your designs as shown here, you will have to rotate the hoop for each design.



Scan the QR code to reach the Design Booklet for your machine.

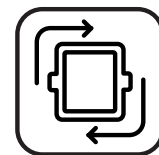

The Turnable Hoop icon will indicate that a design is a turnable design.

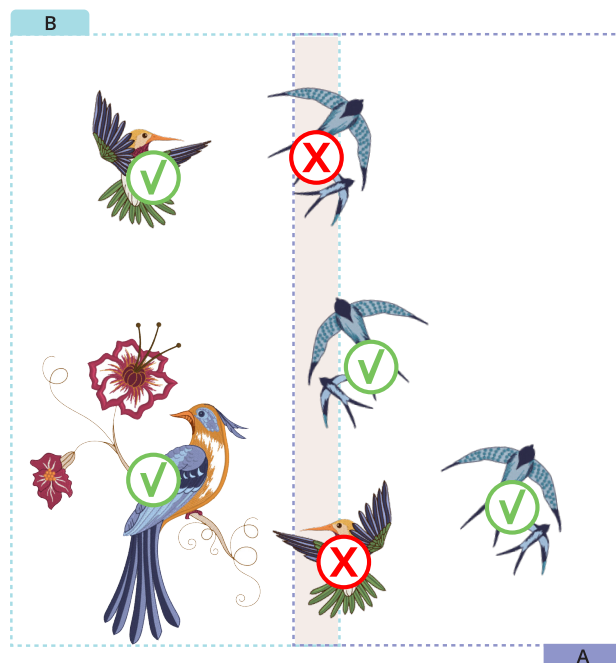

Placement in Embroidery Edit area, designs marked with "✓" is ok and with "X" must be moved to either side.

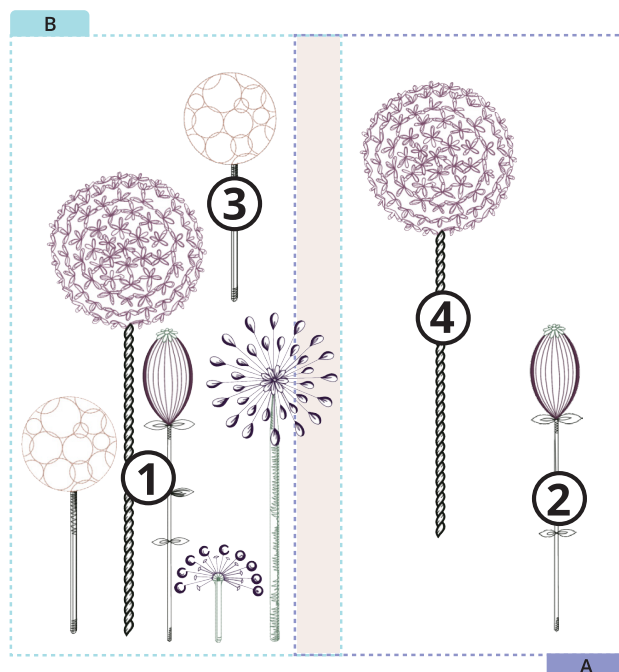

Embroidery Edit

STITCH OUT THE DESIGN

If the first part of the design is placed on the A-side, this will be the first side to be embroidered. If the first design is placed on the B-side (as in the example to the right), that will be the first side.

When the designs are positioned correctly, enter Embroidery Stitch-Out.

The active side of the hoop is highlighted on the screen, the other is inactive.

Note: When the B-side is active, the designs appears rotated on the screen in Embroidery Stitch-Out.

The active side is also indicated by an icon in the secondary top bar.

Attach the corresponding embroidery hoop connector to the embroidery unit.

Basting

If needed, use the basting function before you start to embroider. The basting will be done one side after the other. After basting the first side, a message will appear on screen prompting you to rotate the hoop. Rotate the hoop and continue basting on the other side.

Aligning the Two Parts of the Design

Your machine will guide you through the embroidery process, letting you know when to turn the hoop.

The built-in designs created for the 450x450 mm hoop has alignment stitches at each half of the design. This is to make sure the two halves are properly aligned.

Once the hoop is rotated, step forward in the design (if needed) using the go to stitch + icon until the needle is exactly above the alignment stitch.

Make sure the needle point matches the alignment stitch sewn on the first side. If it doesn't open exact positioning to adjust.

The B-side is highlighted on the screen and in the secondary top bar. Attach the embroidery hoop connector marked "B" to the embroidery unit.

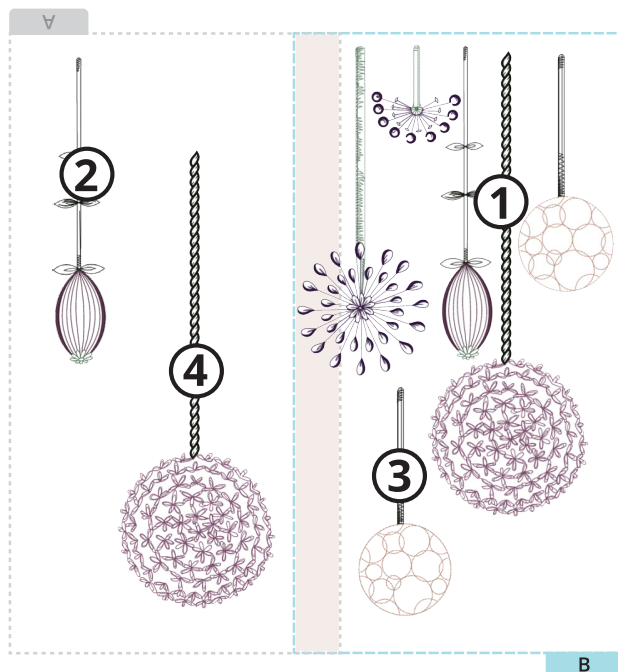

Embroidery Stitch Out: Here, the B-side is highlighted. The first design entered (1) will be the first to be embroidered.



The icon in the secondary top bar indicate what side that is active and should be attached.

